

Compact Radar Level Meter

LPRS80

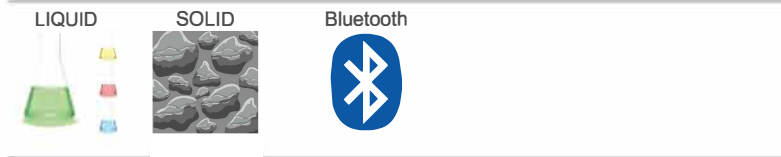

OVERVIEW

Operation

The Radar Level Meters of DESTA 80 GHz series are excellent devices for no contact level measurement. The microwave impulses, emitted by the radar's antenna, travel at speed of light and a part of the energy, reflected by the surface of the medium to be measured, is received by the same antenna.

Features

- Compact design
- No need air purge
- Cost effective
- More application in remote target detection
- Frequency modulation (FCMW radar)
- Higher resolution
- Long distance imaging and multi-spectral imaging

Application

- Sediment, cement etc.
- Simple chemical tanks
- Lift station
- Industrial processes
- River, open channel
- Wet wells

OPERATING DATA

Frequency	76-81 GHz
Temperature Limit	-40...80°C
Installation	BSP 2"
Accuracy	±2 mm
Beam angle	8°
Response Time	<2 s
Process pressure	-1...3 Bar
Resolution	1 mm
Repeatability	±1 mm
Enclosure	IP67/ IP68

MEASURING RANGES

Range	0...10 m
	0...30 m

MATERIALS

Antenna	PP / PVDF
---------	-----------

TECHNICAL DRAWINGS AND DIMENSIONS

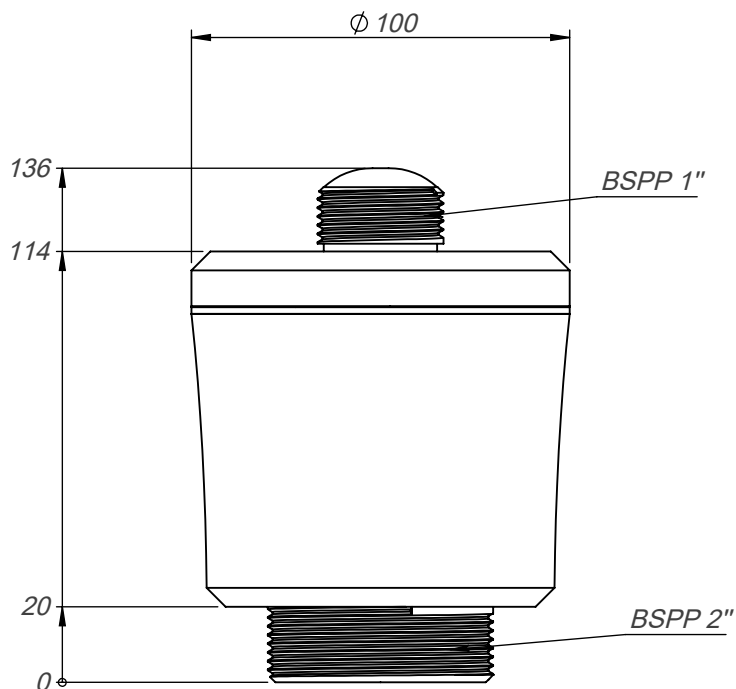

■ INSTALLATION

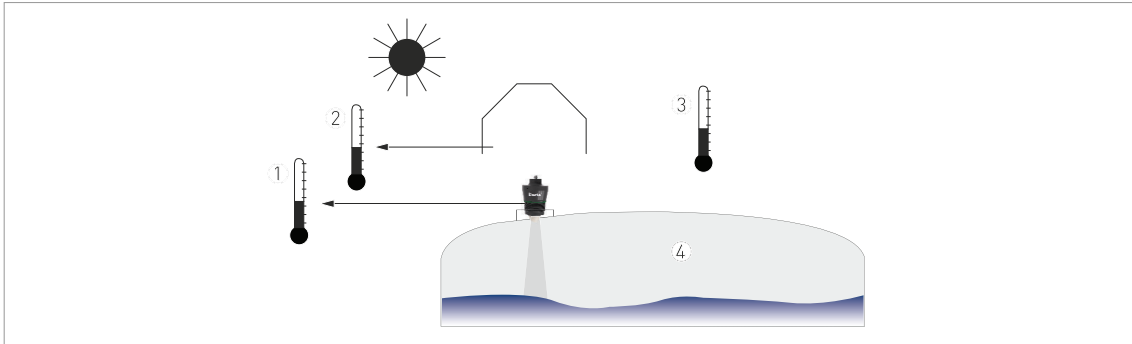

Pressure and temperature ranges

- 1 Temperature at the process connection
- 2 Ambient temperature for operation of the display
- 3 Ambient temperature
- 4 Process pressure

We recommend that you prepare the installation when the tank is empty

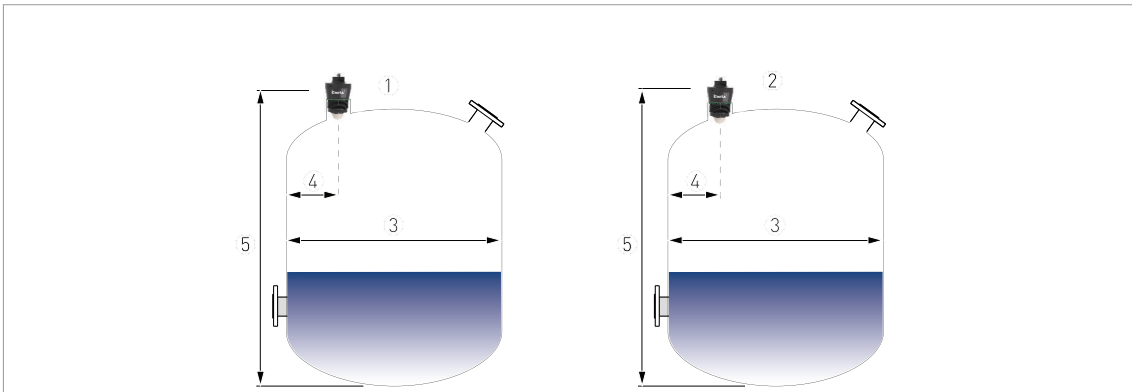

Recommended nozzle position for liquids, pastes and slurries

- 1 Socket for the DN25 Lens antenna
- 2 Socket for the DN40 Lens antenna
- 3 Tank diameter
- 4 Minimum distance of the nozzle or socket from the tank wall
 - DN25 Lens : $1/5 \times$ tank height
 - DN40 Lens: $1/10 \times$ tank height
 - Other Lens: $1/3 \times$ tank diameter
- 5 Tank height

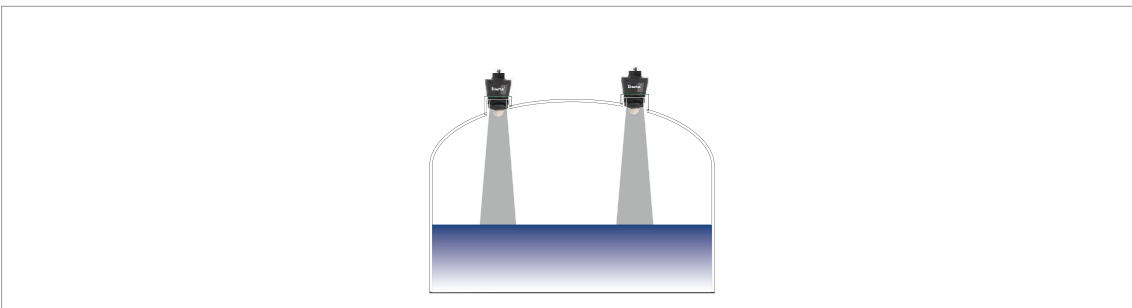

There is no maximum limit to the number of devices that can be operated in the same tank. They can be installed adjacent to other radar level transmitters.

Dish-shaped or conical bottoms have an effect on the measuring range. The device cannot measure to the bottom of the tank. If possible, install the device as shown in the illustration that follows;

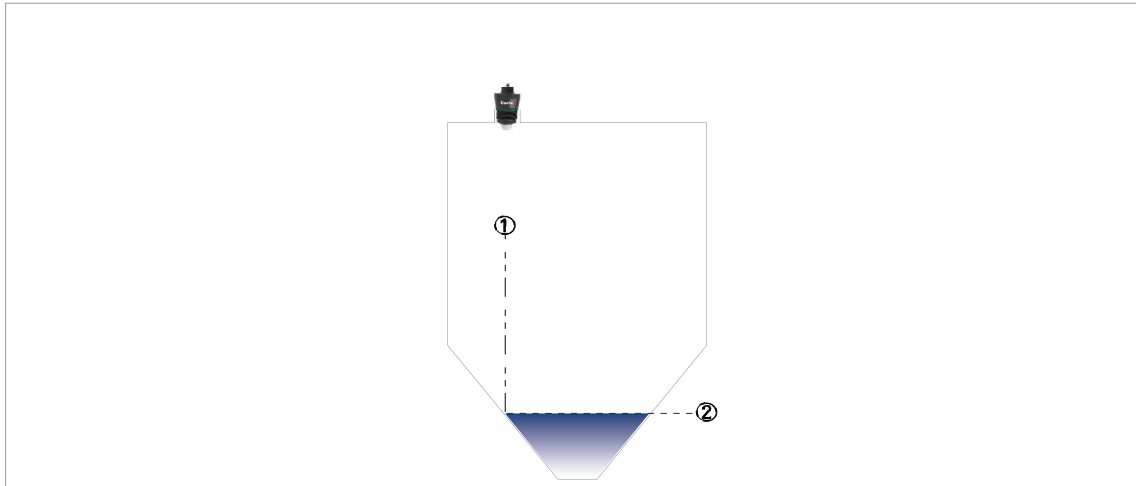

Tanks with dish-shaped or conical bottoms

- 1 Axis of radar beam
- 2 Minimum level reading

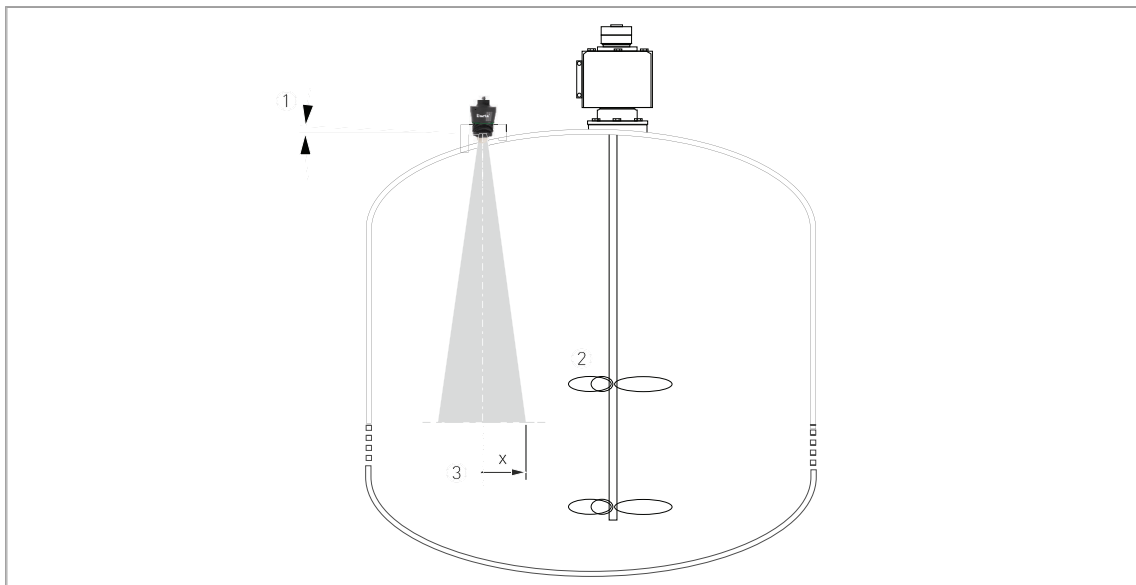

Equipment and obstacles: how to prevent measurement of interference signals

- 1 Do not tilt the device more than 2°
- 2 We recommend that you do an empty spectrum recording
- 3 Beam radius of the antenna The beam radius increases by increments of "x" mm for each metre of distance from the antenna.

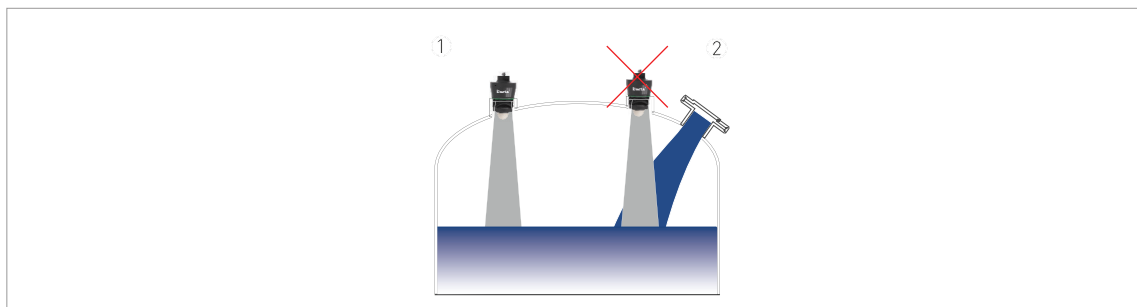

Product inlets

- 1 The device is in the correct position.
- 2 The device is too near to the product inlet.

CAUTION!

Do not put the device near to the product inlet. If the product that enters the tank touches the antenna, the device will measure incorrectly. If the product fills the tank directly below the antenna, the device will also measure incorrectly.

ELECTRICAL DATA

SignalOutput	2-wire 4-20 mA HART MODBUS
Power Supply	18-36 V DC <0.5 W
Electrical Connection	BSPP 1"

COMMUNICATION

On request	RS485 Modbus HART® MODBUS Bluetooth
-------------------	--

ORDERING

LPRS80				Compact Radar Level Meter
Measuring Range	5			0...5 m
	10			0...10 m
	15			0...15 m
	30			0...30 m
Communication		A		4...20 mA
		M		RS485 Modbus
		H		HART
		B		Bluetooth
Electrical Connection		M		M12 Connector
		05		5 m Cable
		10		10 m Cable
		XX		Please specify in order
Enclosure			67	IP67
			68	IP68
Hazardous Area			N	None
			XI	Ex ia IIC T6 Ga